

TELOPEA IN WALL MIXER W/DIVERTER (HANDLE & BACK PLATE)

DETAILS

PRODUCT CODE

TEL-DWM-HBP

DIMENSIONS

62.4mm

INSTALLATION TYPE

Wall Mounted

MATERIAL

Brass

OVERALL DIAMETER

150mm

PRODUCT SERIES

Telopea

WARRANTIES

15 Years

NOTES

PVD products are subject to MOQ

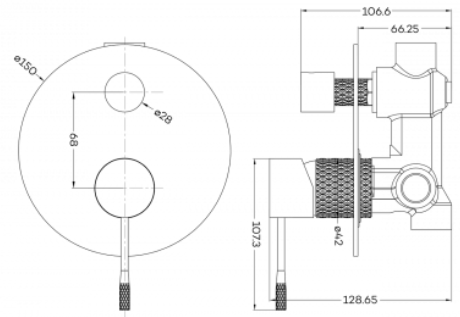

FINISHES

Satin Antique Bronze (SABZ)

Satin Antique Brass (SAB)

Brushed Nickel (BN)

Gold (G)

Graphite (GR)

Gun Metal (GM)

Bronze (BZ)

Rose Gold (RG)

Matte Black (MB)

CERTIFICATIONS

